

## FEATURES

- High voltage capability allows input power bus up to 110VDC and output power up to 900W.
- High performance Linear Servo Amplifier controls brushless linear or rotary motor force or torque
- Linear operating mode does not emit EMI, has high servo stiffness, and no dead zone
- DSP platform provides intelligent control, programmable configuration, fault protection, self-test, calibration, and status reporting
- Accepts sinusoidal commutation signals from a digital motion controller
- Fault protection for amplifier SOA, over and under voltage, temperature, current overloads, and motor shorts
- Seven-segment LED display shows drive status
- Complete operating and fault status via RS-232
- Provides streaming data via I<sup>2</sup>C interface
- System configuration parameters are input digitally via HyperTerminal
- Digital inputs for Enable/Reset, and 4 programmable for Brake, DIR,  $\pm$ Travel Limits
- Offsets are digitally trimmed, providing greater precision and stability than traditional pots
- Operates from one regulated or unregulated DC power supply with internal  $\pm$  12V DC-DC converter
- Enhanced protection with power buss fuse

## APPLICATIONS

- Linear stages, air bearings, and gantry systems
- Semiconductor metrology
- Lithography testing and measurement
- High accuracy assembly/measurement
- Laser machining
- High speed lapping (polishing)

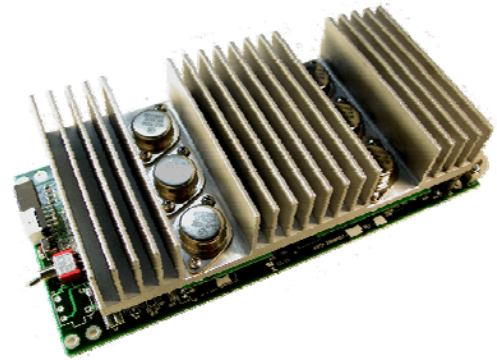

## PRODUCT DESCRIPTION

This size 3U EUROCARD pluggable module provides closed loop four quadrant force or torque control of brushless linear or rotary motors. Based on our popular Series 57 Linear Sine Drive Servo Amplifier, the Series 420 has high voltage capability that allows input power bus up to 110VDC and output power up to 900W.

The Series 420 Sine Drive Linear Amplifier operates with digital motion controllers that generate sinusoidal commutation waveforms using encoder feedback. Two differential amplifiers accept sinusoidal A and B input commands and a high bandwidth current feedback loop is used to transform the input voltage commands to control motor phase A and B current. The amplifier derives phase C current.

Sinusoidal control of brushless DC motors minimizes torque or force ripple. Motor torque or force is approximately constant and independent of position. This is especially important when controlling linear motors in applications requiring smooth constant velocity and micron-positioning accuracy.

The linear operating mode is highly advantageous for noise sensitive applications because it does not generate EMI. PWM switching noise is difficult to eliminate from sensitive sensors and transducers, and degrades velocity and position accuracy.

Excessive power dissipation is the main reliability consideration for linear amplifier operation. The Series 420 uses a digital signal processor (DSP) to monitor the safe operating area (SOA) of the output devices to prevent them from overheating. The Series 420 also includes enhanced protection provided by an on-board power buss fuse.

## GENERAL SPECIFICATIONS

MODEL# →	5-900-110-420A
POWER AMPLIFIER	Linear Sine Drive
PEAK OUTPUT POWER	900 watts <sup>1</sup>
PEAK OUTPUT CURRENT	Up to 5 amps <sup>1</sup> (1 sec typ.)
CONT. OUTPUT CURRENT	Note 1
MAX AMPLIFIER DISSIPATION	200 watts <sup>1</sup>
OUTPUT VOLTAGE @ PEAK CURRENT	105V with 110V Nominal bus
INPUT POWER BUS	75 to 110 VDC
ANALOG SUPPLY <sup>2</sup>	+12 VDC / 0.2 AMPS MAX
ANALOG SUPPLY <sup>2</sup>	-12 VDC / 0.2 AMPS MAX
LOGIC SUPPLY <sup>2</sup>	5 VDC / 0.3 AMPS MAX
INPUT CONTROL LOGIC	5V or 3.3V operation
COMMAND SIGNAL INPUT	± 10V differential
OPERATING TEMPERATURE	0 TO 50 Degrees C <sup>1</sup>
CURRENT COMMAND S.F.	0.5 AMP/VOLT
CURRENT LOOP BANDWIDTH	Adjustable 0.5 to 4 KHZ
SIZE	100 W x 220 L x 56 H mm
WEIGHT	.87 kg (1.92 lb)

**OPERATING CONTROL SIGNALS and INDICATORS**

Input analog A & B control signal <sup>3</sup>	± 10 Volts differential
Peak current limit	Adjustable
Drive Enable/Reset	5V logic or 3.3V
Programmable digital inputs (4):	5V logic or 3.3V
Direction Logic	
(+) Travel Limit	
(-) Travel Limit	
Brake <sup>4</sup>	
Amplifier Status indicator	Seven Segment LED

**AUXILIARY OUTPUTS**

Motor current monitor:	Analog Signal
Drive status 4 outputs:	Digital (mutually exclusive with I <sup>2</sup> C)
Drive fault:	Digital

**SERIAL I/O**

RS232  
I<sup>2</sup>C

**FAULT PROTECTION CIRCUITS**

Safe Operating Area Protection  
Short circuit  
Over temperature<sup>6</sup>  
Over current<sup>6</sup>  
Over / under voltage  
Power buss fuse

NOTES:

1. Depends on ambient operating temperature, motor winding resistance, and heat sink airflow. For the rated maximum controller power dissipation, forced convection cooling with a minimum airflow of 200 CFM is required.

De-rate at 1.7 watts/degree C for ambient greater than 30 degrees C.

Maximum controller dissipation occurs when the power out is minimum (motor stalled).

It can be calculated as follows:

$$P_d = P_{in} - P_{mtr}$$

$$P_{in} = (V_s)(I_o)$$

When operating profile has wide travel range and all 3 phases receive drive current.

$$P_{mtr} = 1.5(I_o)^2(R_t/2)$$

When operating profile has a narrow travel range and only 2 phases receive most of the drive current.

$$P_{mtr} = (I_o)^2(R_t)$$

Where

$P_d$  is controller dissipation in watts

$P_{mtr}$  is motor dissipation in watts

$V_s$  is supply voltage

$I_o$  is the average output current in amps

$R_t$  is motor terminal-to-terminal resistance for a wye winding in ohms.

2. Developed internally from on-board dc-dc converter.
3. Includes A and B  $\pm 1\%$  gain match for precision applications.
4. Actuating brake at high motor speeds may damage the controller or motor. Consult factory for details.
5. Over temperature or over current protection is determined from the DSP monitoring of amplifier operating heat sink temperature and output device power dissipation magnitude versus time. When power device junction over temperature protection is activated, the amplifier output will be disabled. A fault report is available via the RS232 port.
- 6 The on-board power buss fuse is designed to protect the Amplifier from a catastrophic failure. The user should evaluate each application carefully to determine if additional fusing is necessary at the input power connections to the amplifier to protect the Amplifier and any external circuits. See Application Note Supplementary Fuse Protection (which can be viewed at [www.peakservo.com](http://www.peakservo.com)).

### EXTERNAL SIGNALS AND INTERCONNECTIONS

EDGE CONNECTOR J4 IS A 48 POLE DIN 41612 SERIES F  
(REF EPT P/N 109-40064) or (FCI P/N 5159009486394111)

TERMINAL	SIGNAL NAME	DESCRIPTION
J4-2D, B, Z	MTR PHASE A	OUTPUT TO MOTOR PHASE A WINDING
J4-4D, B, Z	VDC POWER BUS RETURN	POWER SUPPLY RETURN
J4-6D, B, Z	MTR PHASE B	OUTPUT TO MOTOR PHASE B WINDING
J4-8D, B, Z	VDC POWER BUS IN	POWER SUPPLY INPUT
J4-10D, B, Z	MTR PHASE C	OUTPUT TO MOTOR PHASE C WINDING
J4-12D	DS1	DRIVE STATUS CODE <7><12>
J4-12B	DS2	DRIVE STATUS CODE <7><12>
J4-12Z	MTR SHIELD	MOTOR SHIELD GND
J4-14D	(+) LIMIT	LOGIC 1= (+) LIMIT, <1>, <3>
J4-14B	MTR CUR	MOTOR CURRENT MONITOR (SEE SECT. 6.0)
J4-14Z	DS4 / SDA	DRIVE STATUS CODE <7> / I <sup>2</sup> C <10><12>
J4-16D	BRAKE CMD	LOGIC 1= BRAKE, <1>, <5>
J4-16B	ENABLE/RESET	LOGIC 0=ENABLE, <1>, <2>
J4-16Z	Vcc OUT	5VDC OUT
J4-18D	(-) LIMIT	LOGIC 1= (-) LIMIT, <1>, <4>
J4-18B	B COMMAND (+)	DIFFERENTIAL ANALOG ± 10V B INPUT COMMAND, <6>
J4-18Z	B COMMAND (-)	DIFFERENTIAL ANALOG ± 10V B INPUT COMMAND, <6>
J4-20D	+12VDC IN	12 V POWER SUPPLY INPUT <9>
J4-20B	DS3 / SCL	DRIVE STATUS CODE <7> / I <sup>2</sup> C <10><12>
J4-20Z	DRIVE FAULT	LOGIC 1= FAULT <8>
J4-22D	DIR LOGIC	INPUT FROM MOTION CONTRL, LOGIC 1=(+) DIRECTION<1>
J4-22B	(-) 12VDC IN	(-) 12 V POWER SUPPLY INPUT <9>
J4-22Z	NC	RESERVED
J4-24D	NC	NO CONNECTION
J4-24B	NC	NO CONNECTION
J4-24Z	NC	RESERVED
J4-26D	A COMMAND (+)	DIFFERENTIAL ANALOG ± 10V A INPUT COMMAND, <6>
J4-26B	A COMMAND (-)	DIFFERENTIAL ANALOG ± 10V A INPUT COMMAND, <6>
J4-26Z	NC	RESERVED
J4-28D	±12V RTN	±12V POWER SUPPLY RETURN
J4-28B	NC	NO CONNECTION
J4-28Z	NC	NO CONNECTION
J4-30D, B	Vcc RTN	5VDC RTN
J4-30Z	NC	NO CONNECTION
J4-32D	CC LIMIT	CC LIMIT, LOGIC 1=CC FAULT <12>
J4-32B	AMP TEMPERATURE FAULT	LOGIC 1=HEAT SINK TEMPERATURE FAULT <7><11><12>
J4-32Z	+5VDC IN	5 V POWER SUPPLY INPUT <9>

NOTES:

- <1> OPTICALLY ISOLATED INPUT WITH INTERNAL 332 OHM PULL-UP RESISTOR TO 5VDC. SEE FUNCTIONAL DIAGRAM.
- <2> SWITCH S1 ON PCB IS IN SERIES WITH THIS LOGIC INPUT CMD. INSTALLATION OF JUMPER JP1 WILL DISABLE THE EXTERNAL CMD.
- <3> (+) LIMIT IS THE TRAVEL LIMIT THE MOTOR WILL DRIVE TOWARD WHEN THE DIRECTION SIGNAL IS A LOGIC 1. INSTALLATION OF JUMPER JP3 WILL DISABLE THIS FEATURE.
- <4> (-) LIMIT IS THE TRAVEL LIMIT THE MOTOR WILL DRIVE TOWARD WHEN THE DIRECTION SIGNAL IS A LOGIC 0. INSTALLATION OF JUMPER JP2 WILL DISABLE THIS FEATURE.
- <5> WHEN ACTIVE, THE MOTOR WINDINGS ARE SHORTED TOGETHER. IF THE BRAKE FEATURE IS NOT REQUIRED, INSTALL JUMPER JP4. CAUTION: BRAKE CMD AT HIGH SPEED MAY DAMAGE MOTOR AND/OR AMPLIFIER. CONSULT FACTORY FOR ASSISTANCE.
- <6> COMMAND POLARITY DETERMINES DIRECTION OF MOTION, SIGNAL AND SIGNAL RETURN CAN BE EXCHANGED. SEE <3>, <4>.
- <7> OUTPUT FROM DIGITAL PROCESSOR. SEE DRIVE STATUS CODE TABLE. 0=TTL LOW, Z=HIGH IMPEDANCE.
- <8> OUTPUT FROM OPTO ISOLATOR. SEE FUNCTIONAL DIAGRAM.
- <9> NOT REQUIRED WHEN OPTIONAL DC-DC CONVERTER IS ORDERED.
- <10> IF I<sup>2</sup>C IS ENABLED, THESE PINS ARE USED WITH I<sup>2</sup>C IN LIEU OF FAULT BUS OUTPUT.
- <11> LIMIT SINK CURRENT TO  $\leq 1\text{ma}$ . JUNCTION TEMP  $>120\text{C}$ , HEAT SINK  $>70\text{C}$ .
- <12> LIMIT SINK CURRENT TO  $\leq 1\text{ma}$ .

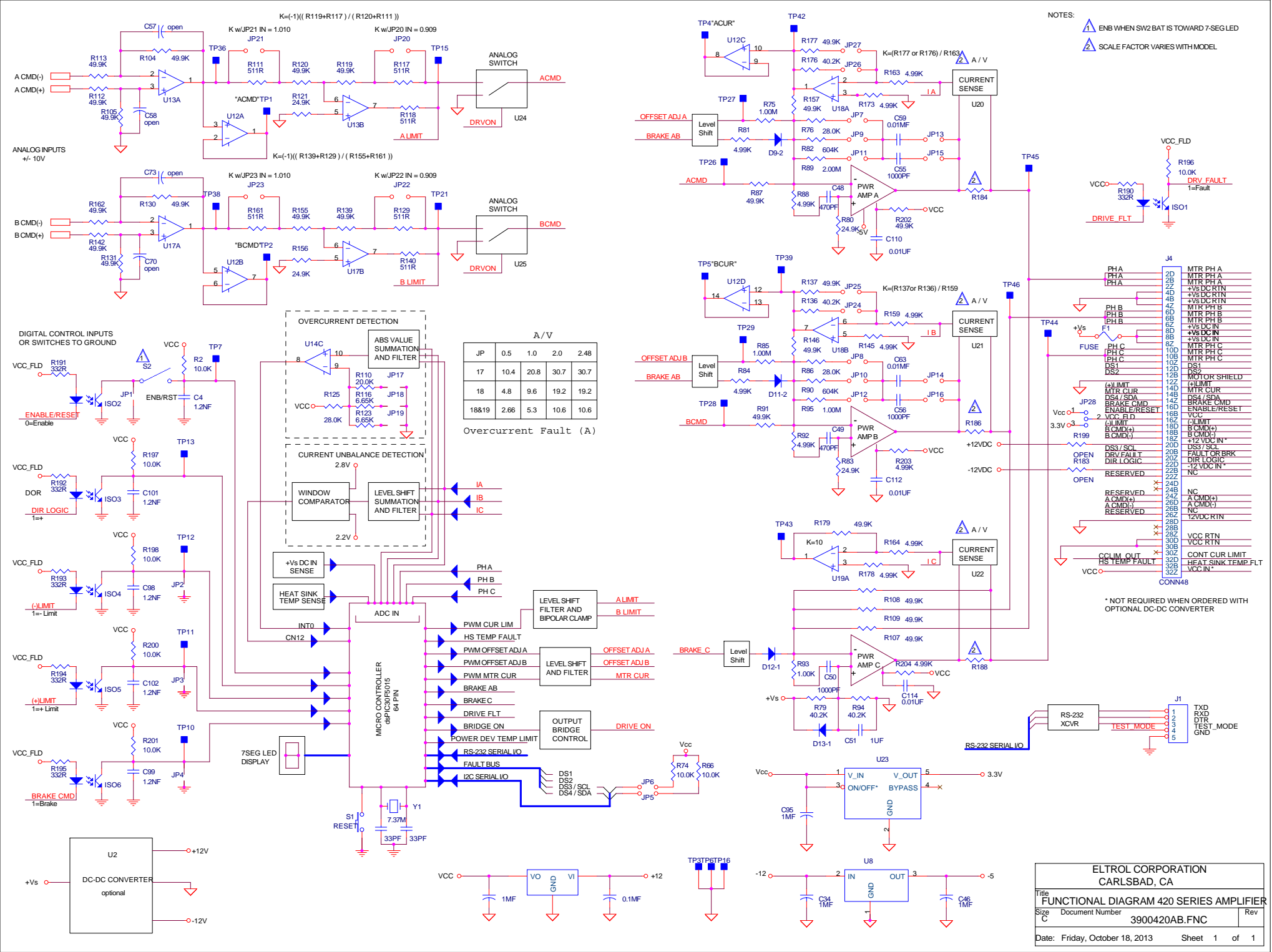

NOTES:  
⚠ ENB WHEN SW2 BAT IS TOWARD 7-SEG LED  
⚠ SCALE FACTOR VARIES WITH MODEL

JP	0.5	1.0	2.0	2.48
17	10.4	20.8	30.7	30.7
18	4.8	9.6	19.2	19.2
188/19	2.66	5.3	10.6	10.6

Overcurrent Fault (A)

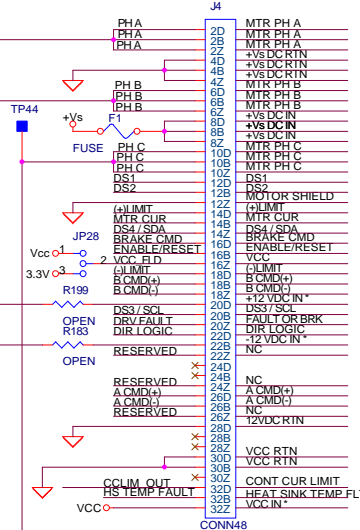

\* NOT REQUIRED WHEN ORDERED WITH OPTIONAL DC-DC CONVERTER

# EUROCARD SERIES 420 LINEAR SINE DRIVE SERVO AMPLIFIER

## MOUNTING DIMENSIONS

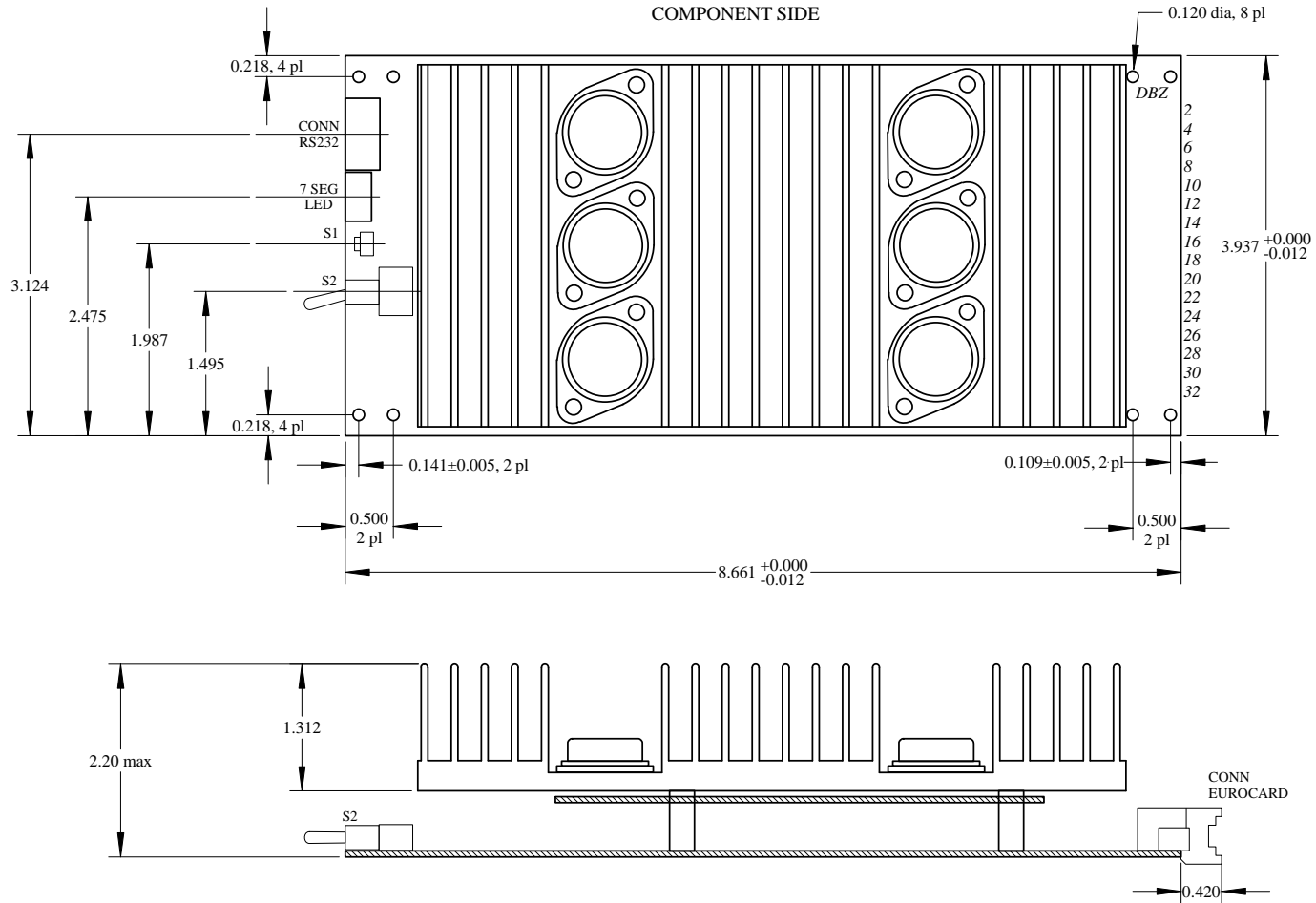

- NOTES:
1. ALL DIMENSIONS SPECIFIED IN INCHES
  2. ALL DIMENSIONS ARE +/- .002 UNLESS OTHERWISE SPECIFIED
  3. DO NOT SCALE

<b>PEAK SERVO CORPORATION</b>	
CARLSBAD, CA	
Title	
SERIES 420 DATA SHEET OUTLINE	
Document Number	Rev
3900420 OUTLINE.TCW	
Date	
March 31, 2014	Sheet 1 of 1