

FEATURES

- High performance Linear Servo Amplifier controls brushless linear or rotary motor force or torque
- Linear operating mode does not emit EMI, has high servo stiffness, and no dead zone
- DSP platform provides intelligent control, programmable configuration, fault protection, self-test, calibration, and status reporting
- Accepts sinusoidal commutation signals from a digital motion controller
- Current loop bandwidth and transconductance, (amps/volt scale factor) are adjustable
- Fault protection for amplifier SOA, over and under voltage, temperature, current overloads, and motor shorts
- Seven-segment LED display shows drive status
- Complete operating and fault status via RS-232
- Provides streaming data via I²C interface
- System configuration parameters are input digitally via HyperTerminal
- Digital inputs for Enable/Reset, and 4 programmable for Brake, DIR, \pm Travel Limits
- Offsets are digitally trimmed, providing greater precision and stability than traditional pots
- Operates with low inductance motors
- High and low supply voltage versions and high and low power versions
- Operates from one regulated or unregulated DC power supply with internal \pm 12V DC-DC converter

APPLICATIONS

- Linear stages, air bearings, and gantry systems
- Semiconductor metrology
- High accuracy assembly/measurement
- Laser machining

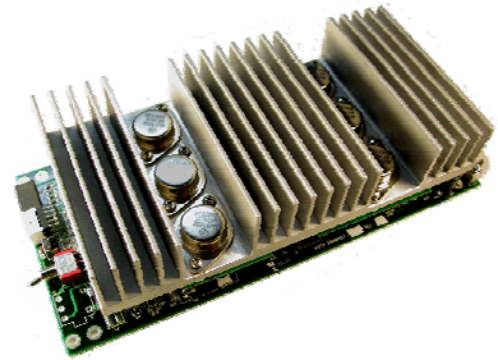

PRODUCT DESCRIPTION

This size 3U EUROCARD provides closed loop four quadrant force or torque control of brushless linear or rotary motors. Smooth velocity and precise nanometer position accuracy can be obtained with sinusoidal control of a linear motor's current.

It operates with digital motion controllers that generate sinusoidal commutation waveforms using encoder feedback. Two differential amplifiers accept sinusoidal A and B input commands. The input commands have a 120 degree phase difference. A high bandwidth current feedback loop is used to transform the input voltage commands to control motor phase A and B current. The amplifier derives phase C current.

Sinusoidal control of brushless DC motors minimizes torque or force ripple. Motor torque or force is approximately constant and independent of position. This is especially important when controlling linear motors in applications requiring smooth constant velocity and micron-positioning accuracy.

The linear operating mode is highly advantageous for noise sensitive applications because it does not generate EMI. PWM switching noise is difficult to eliminate from sensitive sensors and transducers, and degrades velocity and position accuracy.

Excessive power dissipation is the main reliability consideration for linear amplifier operation. This model uses a digital signal processor (DSP) to monitor the safe operating area (SOA) of the output devices to prevent them from overheating and failing.

**LOW VOLTAGE MODELS
GENERAL SPECIFICATIONS**

ELTROL MODEL# →	5-900-048-57E	5-360-048-57F
POWER AMPLIFIER	Linear Mode Drive	Linear Mode Drive
PEAK OUTPUT POWER	900 watts ¹	360 watts ¹
PEAK OUTPUT CURRENT	25 amps ¹ (1 sec typ.)	10 amps ¹ (1 sec typ.)
CONT. OUTPUT CURRENT	Note 1	Note 1
MAX AMPLIFIER DISSIPATION	200 watts ¹	150 watts ¹
OUTPUT VOLTAGE @ PEAK CURRENT	40V with 48V Nominal bus	41V with 48V Nominal bus
INPUT POWER BUS	24 to 60 VDC	24 to 60 VDC
ANALOG SUPPLY ²	+12 VDC/0.5AMPS MAX	+12 VDC/0.5AMPS MAX
ANALOG SUPPLY ²	-12 VDC/0.2AMPS MAX	-12 VDC/0.2AMPS MAX
LOGIC SUPPLY ²	5 VDC / 0.3 AMPS MAX	5 VDC / 0.3 AMPS MAX
INPUT CONTROL LOGIC	Optional 5V or 3.3V	Optional 5V or 3.3V
COMMAND SIGNAL INPUT	± 10V differential	± 10V differential
OPERATING TEMPERATURE	0 TO 50 Degrees C ¹	0 TO 50 Degrees C ¹
CURRENT COMMAND S.F.	2.5 or 2 AMP/VOLT	1 or 0.5 AMP/VOLT
CURRENT LOOP BANDWIDTH	Adjustable 0.5 to 4 KHZ	Adjustable 0.5 to 4 KHZ
SIZE	100 W x 220 L x 56 H mm	100 W x 220 L x 45 H mm
WEIGHT	.87 kg (1.92 lb)	.69 kg (1.53 lb)

**HIGH VOLTAGE MODELS
GENERAL SPECIFICATIONS**

ELTROL MODEL# →	5-1400-080-57G	5-700-080-57H
POWER AMPLIFIER	Linear Mode Drive	Linear Mode Drive
PEAK OUTPUT POWER	1400 watts ¹	700 watts ¹
PEAK OUTPUT CURRENT	20 amps ¹ (1 sec typ.)	10 amps ¹ (1 sec typ.)
CONT. OUTPUT CURRENT	Note 1	Note 1
MAX AMPLIFIER DISSIPATION	200 watts ¹	150 watts ¹
OUTPUT VOLTAGE @ PEAK CURRENT	73V with 80V Nominal bus	73V with 80V Nominal bus
INPUT POWER BUS	36 to 85 VDC	36 to 85 VDC
ANALOG SUPPLY ²	+12 VDC/0.5AMPS MAX	+12 VDC/0.5AMPS MAX
ANALOG SUPPLY ²	-12 VDC/0.2AMPS MAX	-12 VDC/0.2AMPS MAX
LOGIC SUPPLY ²	5 VDC / 0.3 AMPS MAX	5 VDC / 0.3 AMPS MAX
INPUT CONTROL LOGIC	Optional 5V or 3.3V	Optional 5V or 3.3V
COMMAND SIGNAL INPUT	± 10V differential	± 10V differential
OPERATING TEMPERATURE	0 TO 50 Degrees C ¹	0 TO 50 Degrees C ¹
CURRENT COMMAND S.F.	2.5 or 2 AMP/VOLT	1 or 0.5 AMP/VOLT
CURRENT LOOP BANDWIDTH	Adjustable 0.5 to 4 KHZ	Adjustable 0.5 to 4 KHZ
SIZE	100 W x 220 L x 56 H mm	100 W x 220 L x 45 H mm
WEIGHT	.87 kg (1.92 lb)	.69 kg (1.53 lb)

OPERATING CONTROL SIGNALS and INDICATORS

Input analog A & B control signal ³	± 10 Volts differential
Peak current limit	Adjustable
Drive Enable/Reset	5V logic or 3.3V
Programmable digital inputs (4):	5V logic or 3.3V
Direction Logic	
(+) Travel Limit	
(-) Travel Limit	
Brake ⁴	
Amplifier Status indicator	Seven Segment LED

AUXILIARY OUTPUTS

Motor current monitor:	Analog Signal
Drive status 4 outputs:	Digital (mutually exclusive with I ² C)
Drive fault:	Digital

SERIAL I/O

RS232
I²C

FAULT PROTECTION CIRCUITS

Safe Operating Area Protection
Short circuit
Over temperature⁶
Over current⁶
Over / under voltage

NOTES:

1. Depends on ambient operating temperature, motor winding resistance, and heat sink airflow. For the rated maximum controller power dissipation, forced convection cooling with a minimum airflow of 200 CFM is required.

De-rate at 1.7 watts/degree C for ambient greater than 30 degrees C.

Maximum controller dissipation occurs when the power out is minimum (motor stalled).

It can be calculated as follows:

$$P_d = P_{in} - P_{mtr}$$

$$P_{in} = (V_s)(I_o)$$

When operating profile has wide travel range and all 3 phases receive drive current.

$$P_{mtr} = 1.5(I_o)^2(R_t/2)$$

When operating profile has a narrow travel range and only 2 phases receive most of the drive current.

$$P_{mtr} = (I_o)^2(R_t)$$

Where

P_d is controller dissipation in watts

P_{mtr} is motor dissipation in watts

V_s is supply voltage

I_o is the average output current in amps

R_t is motor terminal-to-terminal resistance for a wye winding in ohms.

2. Developed internally from on-board dc-dc converter.
3. Includes A and B $\pm 1\%$ gain match for precision applications.
4. Actuating brake at high motor speeds may damage the controller or motor. Consult factory for details.
5. Over temperature or over current protection is determined from the DSP monitoring of amplifier operating heat sink temperature and output device power dissipation magnitude versus time. When power device junction over temperature protection is activated, the amplifier output will be disabled. A fault report is available via the RS232 port.
6. The user should protect the Amplifier and any external circuits from a catastrophic failure by fusing the input power connections to the amplifier. See Application Note Supplementary Fuse Protection (which can be viewed at www.peakservo.com).

EXTERNAL SIGNALS AND INTERCONNECTIONS

EDGE CONNECTOR J1 IS A 48 POLE DIN 41612 SERIES F
(REF EPT P/N 109-40064) or (FCI P/N 5159009486394111)

TERMINAL	SIGNAL NAME	DESCRIPTION
J1-2D, B, Z	MTR PHASE A	OUTPUT TO MOTOR PHASE A WINDING
J1-4D, B, Z	VDC POWER BUS RETURN	POWER SUPPLY RETURN
J1-6D, B, Z	MTR PHASE B	OUTPUT TO MOTOR PHASE B WINDING
J1-8D, B, Z	VDC POWER BUS IN	POWER SUPPLY INPUT
J1-10D, B, Z	MTR PHASE C	OUTPUT TO MOTOR PHASE C WINDING
J1-12D	DS1	DRIVE STATUS CODE <7>
J1-12B	DS2	DRIVE STATUS CODE <7>
J1-12Z	MTR SHIELD	MOTOR SHIELD GND
J1-14D	(+) LIMIT	LOGIC 1= (+) LIMIT, <1>, <3>
J1-14B	MTR CUR	MOTOR CURRENT MONITOR, SF=SEE FUNC DIAG
J1-14Z	DS4 / SDA	DRIVE STATUS CODE <7> / I ² C <10>
J1-16D	BRAKE CMD	LOGIC 1= BRAKE, <1>, <5>
J1-16B	ENABLE/RESET	LOGIC 0=ENABLE, <1>, <2>
J1-16Z	Vcc OUT	5VDC OUT
J1-18D	(-) LIMIT	LOGIC 1= (-) LIMIT, <1>, <4>
J1-18B	B COMMAND (+)	DIFFERENTIAL ANALOG ± 10V B INPUT COMMAND, <6>
J1-18Z	B COMMAND (-)	DIFFERENTIAL ANALOG ± 10V B INPUT COMMAND, <6>
J1-20D	+12VDC IN	12 V POWER SUPPLY INPUT <9>
J1-20B	DS3 / SCL	DRIVE STATUS CODE <7> / I ² C <10>
J1-20Z	DRIVE FAULT	LOGIC 1= FAULT <8>
J1-22D	DIR LOGIC	INPUT FROM MOTION CONTRL, LOGIC 1=(+) DIRECTION<1>
J1-22B	(-) 12VDC IN	(-) 12 V POWER SUPPLY INPUT <9>
J1-22Z	NC	RESERVED
J1-24D	NC	NO CONNECTION
J1-24B	NC	NO CONNECTION
J1-24Z	NC	RESERVED
J1-26D	A COMMAND (+)	DIFFERENTIAL ANALOG ± 10V A INPUT COMMAND, <6>
J1-26B	A COMMAND (-)	DIFFERENTIAL ANALOG ± 10V A INPUT COMMAND, <6>
J1-26Z	NC	RESERVED
J1-28D	±12V RTN	±12V POWER SUPPLY RETURN
J1-28B	NC	NO CONNECTION
J1-28Z	NC	NO CONNECTION
J1-30D, B	Vcc RTN	5VDC RTN
J1-30Z	NC	NO CONNECTION
J1-32D	CC LIMIT	CC LIMIT, LOGIC 1=CC FAULT <7>
J1-32B	AMP TEMPERATURE FAULT	LOGIC 1=HEAT SINK TEMPERATURE FAULT <7>
J1-32Z	+5VDC IN	5 V POWER SUPPLY INPUT <9>

NOTES:

- <1> OPTICALLY ISOLATED INPUT WITH INTERNAL 332 OHM PULL-UP RESISTOR TO 5VDC. SEE FUNCTIONAL DIAGRAM.
- <2> SWITCH S1 ON PCB IS IN SERIES WITH THIS LOGIC INPUT CMD. INSTALLATION OF JUMPER JP1 WILL DISABLE THE EXTERNAL CMD.
- <3> (+) LIMIT IS THE TRAVEL LIMIT THE MOTOR WILL DRIVE TOWARD WHEN THE DIRECTION SIGNAL IS A LOGIC 1. INSTALLATION OF JUMPER JP3 WILL DISABLE THIS FEATURE.
- <4> (-) LIMIT IS THE TRAVEL LIMIT THE MOTOR WILL DRIVE TOWARD WHEN THE DIRECTION SIGNAL IS A LOGIC 0. INSTALLATION OF JUMPER JP2 WILL DISABLE THIS FEATURE.
- <5> WHEN ACTIVE, THE MOTOR WINDINGS ARE SHORTED TOGETHER. IF THE BRAKE FEATURE IS NOT REQUIRED, INSTALL JUMPER JP4. CAUTION: BRAKE CMD AT HIGH SPEED MAY DAMAGE MOTOR AND/OR CONTROLLER. CONSULT FACTORY FOR ASSISTANCE.
- <6> COMMAND POLARITY DETERMINES DIRECTION OF MOTION, SIGNAL AND SIGNAL RETURN CAN BE EXCHANGED. SEE <3>, <4>.
- <7> OUTPUT FROM DIGITAL PROCESSOR. SEE DRIVE STATUS CODE TABLE. 0=TTL LOW, Z=HIGH IMPEDANCE.
LIMIT SINK CURRENT TO $\leq 1\text{ma}$. JUNCTION TEMP $>120\text{C}$, HEAT SINK $>70\text{C}$
- <8> OUTPUT FROM OPTO ISOLATOR. SEE FUNCTIONAL DIAGRAM.
- <9> NOT REQUIRED WHEN OPTIONAL DC-DC CONVERTER IS ORDERED.
- <10> IF I²C IS ENABLED, THESE PINS ARE USED WITH I²C IN LIEU OF FAULT BUS OUTPUT.

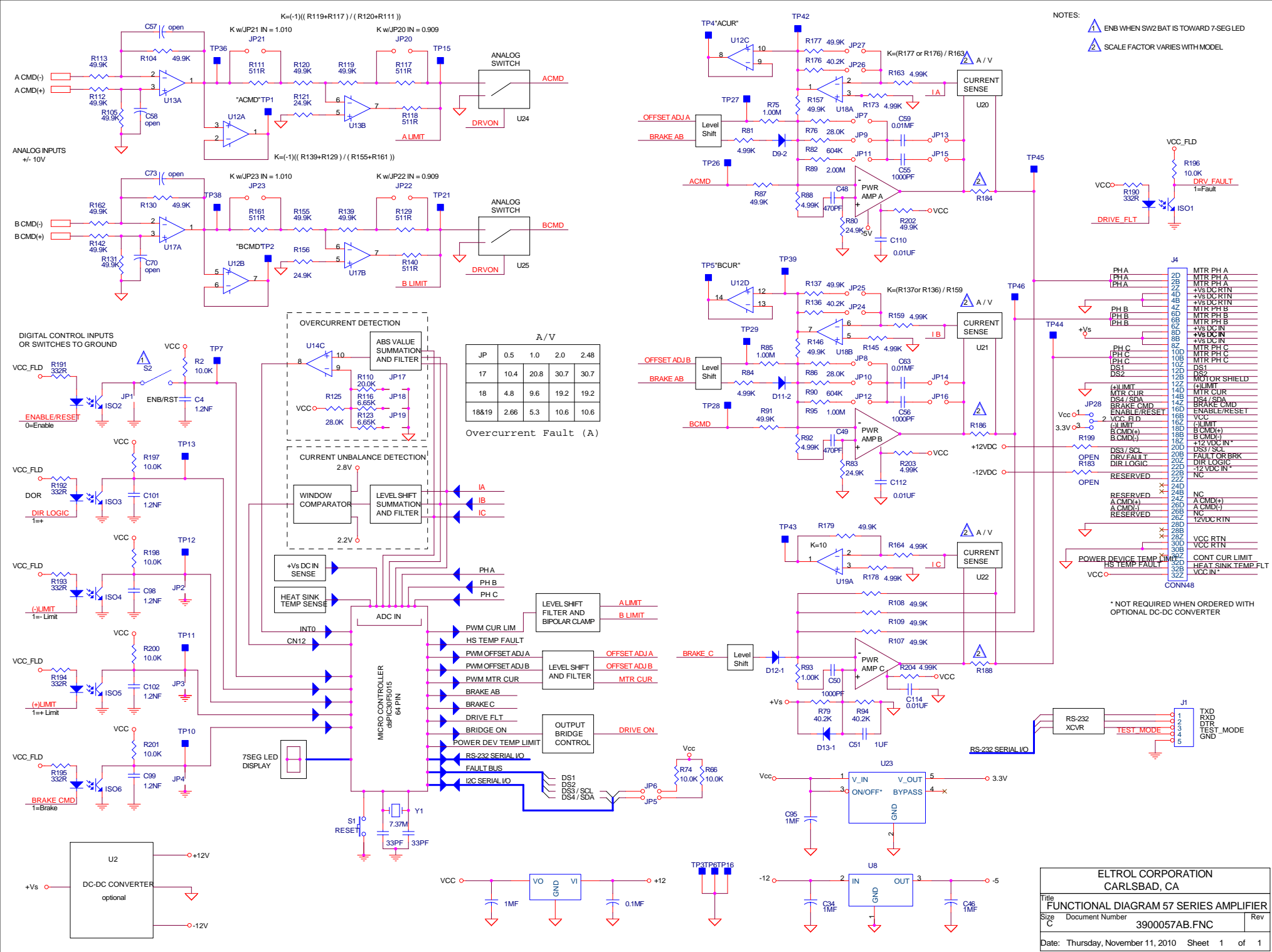

NOTES:
 ⚠ ENB WHEN SW2 BAT IS TOWARD 7-SEG LED
 ⚠ SCALE FACTOR VARIES WITH MODEL

A/V

JP	0.5	1.0	2.0	2.48
17	10.4	20.8	30.7	30.7
18	4.8	9.6	19.2	19.2
18819	2.66	5.3	10.6	10.6

Overcurrent Fault (A)

J4

2D	MTR PH A
2E	MTR PH A
4D	+V5 DC RTN
4B	+V5 DC RTN
4C	+V5 DC IN
6D	MTR PH B
6E	MTR PH B
6C	+V5 DC IN
8D	+V5 DC IN
8E	MTR PH C
10D	MTR PH C
10C	MTR PH C
10E	DS1
12B	DOCTOR SHIELD
122	(+LIMIT
14D	MTR CUR
14B	DS4/SDA
14C	BRAKE CMD
16B	ENABLE/RESET
16D	VCC
18D	(-LIMIT
18B	B CMD(+)
18C	B CMD(-)
20D	+12VDC IN*
20B	DIR LOGIC
22D	FAULT OR BRK
22B	DIR LOGIC
22C	+12VDC IN*
22E	NC
24D	NC
24B	A CMD(+)
24C	A CMD(-)
26B	A CMD(-)
26C	NC
26E	+12VDC RTN
28D	VCC RTN
28C	VCC RTN
30D	VCC RTN
30B	CONT CUR LIMIT
32B	HEAT SINK TEMP FLT
32E	VCC IN*

* NOT REQUIRED WHEN ORDERED WITH OPTIONAL DC-DC CONVERTER

EUROCARD SERIES 57 LINEAR SINE DRIVE SERVO AMPLIFIER

MOUNTING DIMENSIONS

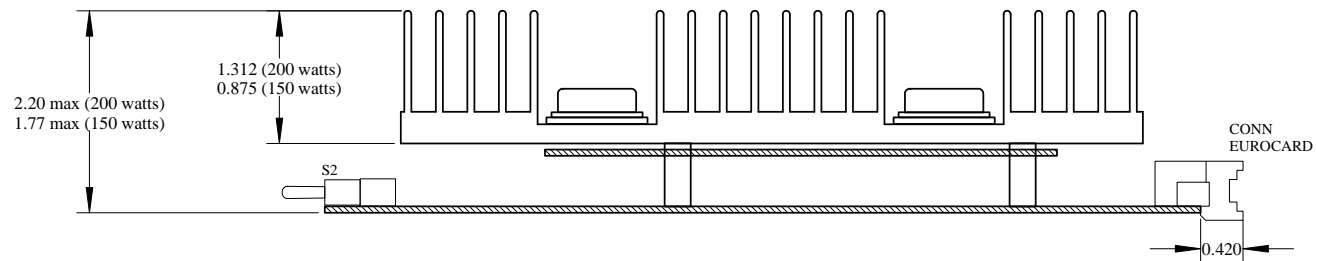
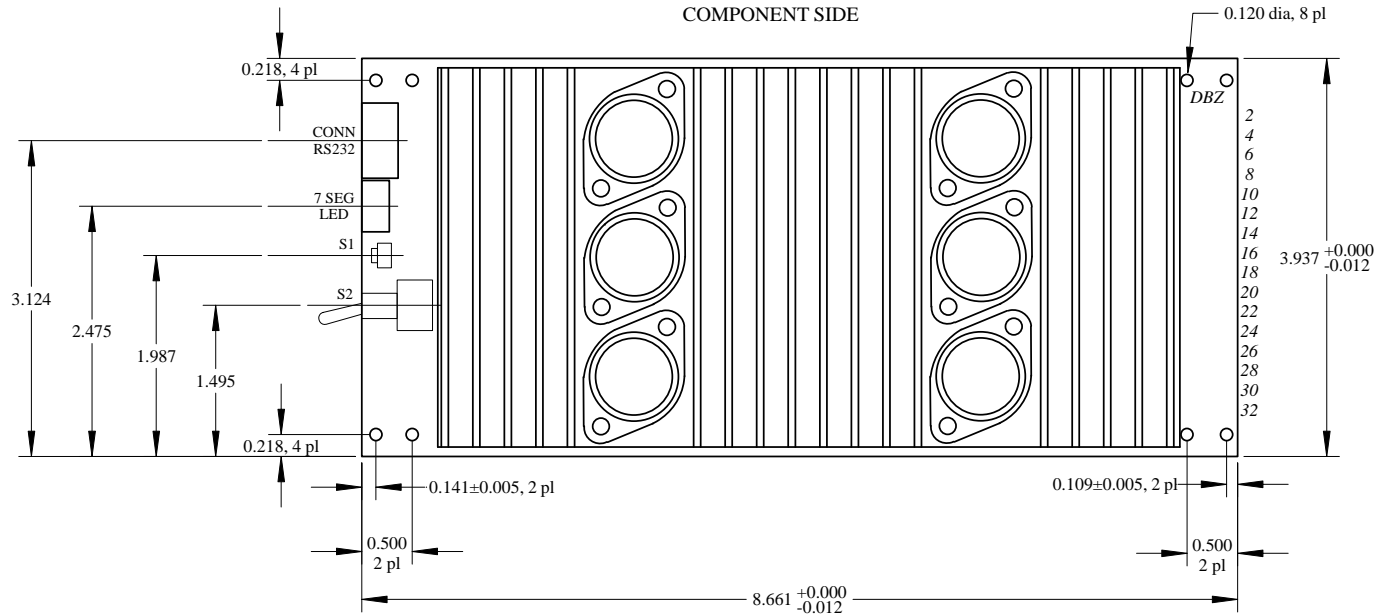

- NOTES:
1. ALL DIMENSIONS SPECIFIED IN INCHES
 2. ALL DIMENSIONS ARE +/- .002 UNLESS OTHERWISE SPECIFIED
 3. DO NOT SCALE

ELTROL CORPORATION	
CARLSBAD, CA	
Title	
SERIES 57 DATA SHEET OUTLINE	
Document Number	Rev
3900057 OUTLINE.TCW	
Date	
April 23, 2008	Sheet 1 of 1