

EUROCARD SERIES 52 LINEAR DC SERVO AMPLIFIER

FEATURES

- High performance Linear Servo Amplifier controls DC brush motor torque or linear motor force
- Linear operating mode does not emit EMI, has high servo stiffness, and no dead zone
- Accepts analog command signals from a digital motion controller
- Operates with low inductance motors
- Current loop bandwidth and the transconductance, amps/volt scale factor, are adjustable
- Fault protection for amplifier over temperature, current overloads, and motor shorts
- Digital inputs for Enable/Reset, Brake, and \pm Travel Limits

APPLICATIONS

- Linear stages, air bearings, and gantry systems
- Integrated circuit manufacturing and inspection
- High accuracy electronic assembly
- High accuracy measurement
- Laser Machining
- Voice coil motors
- Optics positioners
- DC torque motors



PRODUCT DESCRIPTION

This size 3U EUROCARD provides closed loop four quadrant torque or force control of DC brush rotary servo, torque motors, linear motors, and voice coil motors.

Linear control of DC brush or linear motors is especially important for high performance position or velocity control systems. The pure DC form factor allows high current loop bandwidth.

The linear operating mode is highly advantageous for noise sensitive applications because it does not generate EMI. PWM switching noise is difficult to eliminate from sensitive sensors and transducers. This degrades velocity and position accuracy.

The controller employs two-stage current limiting. The first stage is a peak level with a time limit, then the second stage activates for a lower continuous current limit. A jumper selects the option of disabling the output when the continuous current limit is tripped. A trim potentiometer allows adjustment of the peak current up to the maximum value.

EUROCARD SERIES 52 LINEAR DC SERVO AMPLIFIER

GENERAL SPECIFICATIONS

MODEL	6-420-048-01	6-714-048-01
PEAK OUTPUT POWER	400 watts ¹	700 watts ¹
PEAK OUTPUT CURRENT	10 amps ¹ (1 sec typ.)	17 amps ¹ (1 sec typ.)
CONT. OUTPUT CURRENT	Note 1	Note 1
MAX CONTROLLER DISSIPATION	98 watts ¹	140 watts ¹
OUTPUT VOLTAGE @ CONT. OUTPUT CURRENT	22V with 28V nominal bus	42V with 48V nominal bus
INPUT POWER BUS ³	24 to 56 VDC	24 to 56 VDC
INPUT ANALOG P.S.	±12 VDC	±12 VDC
POWER AMPLIFIER	Linear Mode Drive	
OPERATING TEMPERATURE	0 TO 50 Degrees C ¹	
CURRENT LOOP BANDWIDTH	Adjustable 0.5 to 4 KHZ typical	
LOGIC SUPPLY	5 VDC developed internally	
SIZE	100 W x 220 L x 44 H mm	
WEIGHT	.737 kg (26 oz)	

OPERATING CONTROL SIGNALS and INDICATORS

Input analog control signal	± 10 Volts differential
Peak current limit	Adjustable
Drive Enable/Reset	5V logic
Direction Logic	5V logic
(+) Travel Limit	5V logic
(-) Travel Limit	5V logic
Brake ²	5V logic
Fault and/or Brake status	5V logic
Brake indicator	LED
Fault indicator	LED

AUXILIARY OUTPUTS

Motor current monitor: Analog Signal

FAULT PROTECTION CIRCUITS

Controller over temperature
Over current

EUROCARD SERIES 52 LINEAR DC SERVO AMPLIFIER

GENERAL SPECIFICATIONS

Notes:

1. Depends on ambient operating temperature, motor winding resistance, and heat sink airflow. For the rated maximum controller power dissipation, forced convection cooling with a minimum airflow of 100 CFM is required. Derate at 3 watts/degree C for ambient greater than 30 degrees C. Maximum controller dissipation occurs when the power out is minimum (motor stalled). It can be calculated as follows:

$$P_d = P_{in} - P_{mtr}$$

$$P_{in} = (V_s)(I_o)$$

$$P_{mtr} = (I_o)^2(R_t)$$

Where

P_d is controller dissipation in watts

P_{in} is input power

P_{mtr} is motor dissipation in watts

V_s is supply voltage

I_o is output current in amps

R_t is motor terminal-to-terminal resistance in ohms.

Consult factory for assistance.

The controller employs two stage current limiting. The first stage is a peak level with a time limit, then the second stage activates for a lower continuous current limit.

2. Actuating brake at high motor speeds may damage the controller or motor. Consult factory for details.

3. The user should protect the Amplifier and any external circuits from a catastrophic failure by fusing the input power connections to the amplifier. See Application Note Supplementary Fuse Protection.

EUROCARD SERIES 52 LINEAR DC SERVO AMPLIFIER

EXTERNAL SIGNALS AND INTERCONNECTIONS

EDGE CONNECTOR J1 IS A 48 POLE DIN 41612 SERIES F
(REF EPT P/N 109-40064) or (FCI P/N 5159009486394111)

TERMINAL	SIGNAL NAME	DESCRIPTION
J1-2D, B, Z	MTR (+)	OUTPUT TO MOTOR (+) TERMINAL
J1-4D, B, Z	VDC POWER BUS RETURN	POWER SUPPLY RETURN
J1-6D, B, Z	NC	NO CONNECTION
J1-8D, B, Z	VDC POWER BUS IN	POWER SUPPLY INPUT, <9>
J1-10D, B, Z	MTR (-)	OUTPUT TO MOTOR (-) TERMINAL
J1-12D	NC	NO CONNECTION
J1-12B	NC	NO CONNECTION
J1-12Z	MTR SHIELD	MOTOR SHIELD GND
J1-14D	(+) LIMIT	LOGIC 1= (+) LIMIT, <1>, <3>
J1-14B	MTR CUR	MOTOR CURRENT MONITOR, SF=SEE FUNC DIAG
J1-14Z	NC	NO CONNECTION
J1-16D	BRAKE CMD	LOGIC 1= BRAKE, <1>, <5>, <8>
J1-16B	ENABLE/RESET	LOGIC 0=ENABLE, <1>, <2>
J1-16Z	Vcc OUT	5VDC OUT
J1-18D	(-) LIMIT	LOGIC 1= (-) LIMIT, <1>, <4>
J1-18B	NC	NO CONNECTION
J1-18Z	NC	NO CONNECTION
J1-20D	+12VDC IN	12 V POWER SUPPLY INPUT
J1-20B	CURRENT FAULT OUT	LOGIC 1= CUR FAULT, <7>
J1-20Z	FAULT &/OR BRAKE OUT	LOGIC 1= FAULT AND, OR BRAKE ON <7>
J1-22D	DIR LOGIC	INPUT FROM MOTION CONTROLLER, LOGIC 1=(+) DIRECTION ¹
J1-22B	(-) 12VDC IN	(-) 12 V POWER SUPPLY INPUT
J1-22Z	NC	NO CONNECTION
J1-24D	NC	NO CONNECTION
J1-24B	NC	NO CONNECTION
J1-24Z	NC	NO CONNECTION
J1-26D	A COMMAND (+)	DIFFERENTIAL ANALOG \pm 10V A INPUT COMMAND, <6>
J1-26B	A COMMAND (-)	DIFFERENTIAL ANALOG \pm 10V A INPUT COMMAND, <6>
J1-26Z	NC	NO CONNECTION
J1-28D	\pm 12V RTN	\pm 12V POWER SUPPLY RETURN
J1-28B	NC	NO CONNECTION
J1-28Z	NC	NO CONNECTION
J1-30D	Vcc RTN OUT	5VDC RTN OUT
J1-30B	Vcc RTN OUT	5VDC RTN OUT
J1-30Z	NC	NO CONNECTION
J1-32D	CONT CUR FAULT	CONTINUOUS CURRENT FAULT, LOGIC 1=CC FAULT <7>
J1-32B	TEMPERATURE FAULT	LOGIC 1=TEMPERATURE FAULT <7>
J1-32Z	NC	NO CONNECTION

NOTES:

<1> INTERNAL 10K PULL-UP RESISTOR TO 5VDC.

<2> SWITCH S1 ON PCB IS IN SERIES WITH THIS LOGIC INPUT CMD. INSTALLATION OF JUMPER JP6 WILL DISABLE THE EXTERNAL CMD.

<3> (+) LIMIT IS THE TRAVEL LIMIT THE MOTOR WILL DRIVE TOWARD WHEN THE DIRECTION SIGNAL IS A LOGIC 1. INSTALLATION OF JUMPER JP1 WILL DISABLE THIS FEATURE.

<4> (-) LIMIT IS THE TRAVEL LIMIT THE MOTOR WILL DRIVE TOWARD WHEN THE DIRECTION SIGNAL IS A LOGIC 0. INSTALLATION OF JUMPER JP2 WILL DISABLE THIS FEATURE.

<5> WHEN ACTIVE, THE MOTOR WINDINGS ARE SHORTED TOGETHER. IF THE BRAKE FEATURE IS NOT REQUIRED, INSTALL JUMPER JP3. CAUTION: BRAKE CMD AT HIGH SPEED MAY DAMAGE MOTOR AND/OR CONTROLLER. CONSULT FACTORY FOR ASSISTANCE.

<6> COMMAND POLARITY DETERMINES DIRECTION OF ROTATION, SIGNAL AND SIGNAL RETURN CAN BE EXCHANGED. SEE <3>, <4>.

<7> OUTPUT FROM CMOS PLD.

<8> WE RECOMMEND THAT THE BRAKE CMD BE APPLIED FOR "POWER UP" AND THEN REMOVED FOR NORMAL OPERATION.

<9> SEE APPLICATION NOTE SUPPLEMENTARY FUSE PROTECTION.

5661 PALMER WAY #E, CARLSBAD, CA 92010

TEL: (760)438-4986 FAX: (760)438-4987 Email: sales@eltrol.com

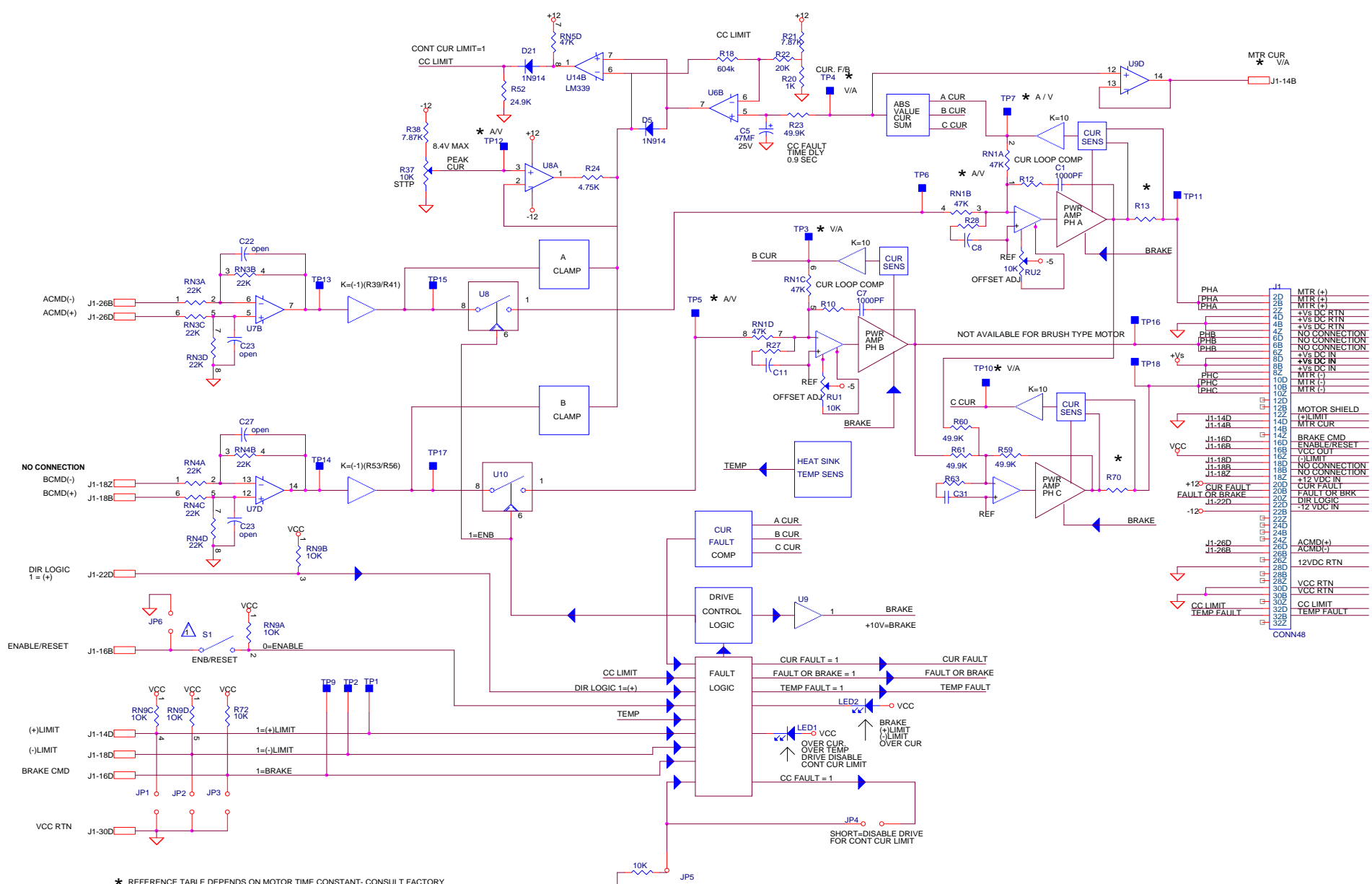

20	MTR (+)
21	MTR (-)
22	+5V DC RTN
23	+5V DC IN
24	+5V DC RTN
25	+5V DC IN
26	+5V DC RTN
27	+5V DC IN
28	+5V DC RTN
29	+5V DC IN
30	+5V DC RTN
31	+5V DC IN
32	+5V DC RTN
33	+5V DC IN
34	+5V DC RTN
35	+5V DC IN
36	+5V DC RTN
37	+5V DC IN
38	+5V DC RTN
39	+5V DC IN
40	+5V DC RTN
41	+5V DC IN
42	+5V DC RTN
43	+5V DC IN
44	+5V DC RTN
45	+5V DC IN
46	+5V DC RTN
47	+5V DC IN
48	+5V DC RTN
49	+5V DC IN
50	+5V DC RTN
51	+5V DC IN
52	+5V DC RTN
53	+5V DC IN
54	+5V DC RTN
55	+5V DC IN
56	+5V DC RTN
57	+5V DC IN
58	+5V DC RTN
59	+5V DC IN
60	+5V DC RTN
61	+5V DC IN
62	+5V DC RTN
63	+5V DC IN
64	+5V DC RTN
65	+5V DC IN
66	+5V DC RTN
67	+5V DC IN
68	+5V DC RTN
69	+5V DC IN
70	+5V DC RTN
71	+5V DC IN
72	+5V DC RTN
73	+5V DC IN
74	+5V DC RTN
75	+5V DC IN
76	+5V DC RTN
77	+5V DC IN
78	+5V DC RTN
79	+5V DC IN
80	+5V DC RTN
81	+5V DC IN
82	+5V DC RTN
83	+5V DC IN
84	+5V DC RTN
85	+5V DC IN
86	+5V DC RTN
87	+5V DC IN
88	+5V DC RTN
89	+5V DC IN
90	+5V DC RTN
91	+5V DC IN
92	+5V DC RTN
93	+5V DC IN
94	+5V DC RTN
95	+5V DC IN
96	+5V DC RTN
97	+5V DC IN
98	+5V DC RTN
99	+5V DC IN
100	+5V DC RTN
101	+5V DC IN
102	+5V DC RTN
103	+5V DC IN
104	+5V DC RTN
105	+5V DC IN
106	+5V DC RTN
107	+5V DC IN
108	+5V DC RTN
109	+5V DC IN
110	+5V DC RTN
111	+5V DC IN
112	+5V DC RTN
113	+5V DC IN
114	+5V DC RTN
115	+5V DC IN
116	+5V DC RTN
117	+5V DC IN
118	+5V DC RTN
119	+5V DC IN
120	+5V DC RTN
121	+5V DC IN
122	+5V DC RTN
123	+5V DC IN
124	+5V DC RTN
125	+5V DC IN
126	+5V DC RTN
127	+5V DC IN
128	+5V DC RTN
129	+5V DC IN
130	+5V DC RTN
131	+5V DC IN
132	+5V DC RTN
133	+5V DC IN
134	+5V DC RTN
135	+5V DC IN
136	+5V DC RTN
137	+5V DC IN
138	+5V DC RTN
139	+5V DC IN
140	+5V DC RTN
141	+5V DC IN
142	+5V DC RTN
143	+5V DC IN
144	+5V DC RTN
145	+5V DC IN
146	+5V DC RTN
147	+5V DC IN
148	+5V DC RTN
149	+5V DC IN
150	+5V DC RTN
151	+5V DC IN
152	+5V DC RTN
153	+5V DC IN
154	+5V DC RTN
155	+5V DC IN
156	+5V DC RTN
157	+5V DC IN
158	+5V DC RTN
159	+5V DC IN
160	+5V DC RTN
161	+5V DC IN
162	+5V DC RTN
163	+5V DC IN
164	+5V DC RTN
165	+5V DC IN
166	+5V DC RTN
167	+5V DC IN
168	+5V DC RTN
169	+5V DC IN
170	+5V DC RTN
171	+5V DC IN
172	+5V DC RTN
173	+5V DC IN
174	+5V DC RTN
175	+5V DC IN
176	+5V DC RTN
177	+5V DC IN
178	+5V DC RTN
179	+5V DC IN
180	+5V DC RTN
181	+5V DC IN
182	+5V DC RTN
183	+5V DC IN
184	+5V DC RTN
185	+5V DC IN
186	+5V DC RTN
187	+5V DC IN
188	+5V DC RTN
189	+5V DC IN
190	+5V DC RTN
191	+5V DC IN
192	+5V DC RTN
193	+5V DC IN
194	+5V DC RTN
195	+5V DC IN
196	+5V DC RTN
197	+5V DC IN
198	+5V DC RTN
199	+5V DC IN
200	+5V DC RTN
201	+5V DC IN
202	+5V DC RTN
203	+5V DC IN
204	+5V DC RTN
205	+5V DC IN
206	+5V DC RTN
207	+5V DC IN
208	+5V DC RTN
209	+5V DC IN
210	+5V DC RTN
211	+5V DC IN
212	+5V DC RTN
213	+5V DC IN
214	+5V DC RTN
215	+5V DC IN
216	+5V DC RTN
217	+5V DC IN
218	+5V DC RTN
219	+5V DC IN
220	+5V DC RTN
221	+5V DC IN
222	+5V DC RTN
223	+5V DC IN
224	+5V DC RTN
225	+5V DC IN
226	+5V DC RTN
227	+5V DC IN
228	+5V DC RTN
229	+5V DC IN
230	+5V DC RTN
231	+5V DC IN
232	+5V DC RTN
233	+5V DC IN
234	+5V DC RTN
235	+5V DC IN
236	+5V DC RTN
237	+5V DC IN
238	+5V DC RTN
239	+5V DC IN
240	+5V DC RTN
241	+5V DC IN
242	+5V DC RTN
243	+5V DC IN
244	+5V DC RTN
245	+5V DC IN
246	+5V DC RTN
247	+5V DC IN
248	+5V DC RTN
249	+5V DC IN
250	+5V DC RTN
251	+5V DC IN
252	+5V DC RTN
253	+5V DC IN
254	+5V DC RTN
255	+5V DC IN
256	+5V DC RTN
257	+5V DC IN
258	+5V DC RTN
259	+5V DC IN
260	+5V DC RTN
261	+5V DC IN
262	+5V DC RTN
263	+5V DC IN
264	+5V DC RTN
265	+5V DC IN
266	+5V DC RTN
267	+5V DC IN
268	+5V DC RTN
269	+5V DC IN
270	+5V DC RTN
271	+5V DC IN
272	+5V DC RTN
273	+5V DC IN
274	+5V DC RTN
275	+5V DC IN
276	+5V DC RTN
277	+5V DC IN
278	+5V DC RTN
279	+5V DC IN
280	+5V DC RTN
281	+5V DC IN
282	+5V DC RTN
283	+5V DC IN
284	+5V DC RTN
285	+5V DC IN
286	+5V DC RTN
287	+5V DC IN
288	+5V DC RTN
289	+5V DC IN
290	+5V DC RTN
291	+5V DC IN
292	+5V DC RTN
293	+5V DC IN
294	+5V DC RTN
295	+5V DC IN
296	+5V DC RTN
297	+5V DC IN
298	+5V DC RTN
299	+5V DC IN
300	+5V DC RTN
301	+5V DC IN
302	+5V DC RTN
303	+5V DC IN
304	+5V DC RTN
305	+5V DC IN
306	+5V DC RTN
307	+5V DC IN
308	+5V DC RTN
309	+5V DC IN
310	+5V DC RTN
311	+5V DC IN
312	+5V DC RTN
313	+5V DC IN
314	+5V DC RTN
315	+5V DC IN
316	+5V DC RTN
317	+5V DC IN
318	+5V DC RTN
319	+5V DC IN
320	+5V DC RTN
321	+5V DC IN
322	+5V DC RTN
323	+5V DC IN
324	+5V DC RTN
325	+5V DC IN
326	+5V DC RTN
327	+5V DC IN
328	+5V DC RTN
329	+5V DC IN
330	+5V DC RTN
331	+5V DC IN
332	+5V DC RTN
333	+5V DC IN
334	+5V DC RTN
335	+5V DC IN
336	+5V DC RTN
337	+5V DC IN
338	+5V DC RTN
339	+5V DC IN
340	+5V DC RTN
341	+5V DC IN
342	+5V DC RTN
343	+5V DC IN
344	+5V DC RTN
345	+5V DC IN
346	+5V DC RTN
347	+5V DC IN
348	+5V DC RTN
349	+5V DC IN
350	+5V DC RTN
351	+5V DC IN
352	+5V DC RTN
353	+5V DC IN
354	+5V DC RTN
355	+5V DC IN
356	+5V DC RTN
357	+5V DC IN
358	+5V DC RTN
359	+5V DC IN
360	+5V DC RTN
361	+5V DC IN
362	+5V DC RTN
363	+5V DC IN
364	+5V DC RTN
365	+5V DC IN
366	+5V DC RTN
367	+5V DC IN
368	+5V DC RTN
369	+5V DC IN
370	+5V DC RTN
371	+5V DC IN
372	+5V DC RTN
373	+5V DC IN
374	+5V DC RTN
375	+5V DC IN
376	+5V DC RTN
377	+5V DC IN
378	+5V DC RTN
379	+5V DC IN
380	+5V DC RTN
381	+5V DC IN
382	+5V DC RTN
383	+5V DC IN
384	+5V DC RTN
385	+5V DC IN
386	+5V DC RTN
387	+5V DC IN
388	+5V DC RTN
389	+5V DC IN
390	+5V DC RTN
391	+5V DC IN
392	+5V DC RTN
393	+5V DC IN
394	+5V DC RTN
395	+5V DC IN
396	+5V DC RTN
397	+5V DC IN
398	+5V DC RTN
399	+5V DC IN
400	+5V DC RTN
401	+5V DC IN
402	+5V DC RTN
403	+5V DC IN
404	+5V DC RTN
405	+5V DC IN
406	+5V DC RTN
407	+5V DC IN
408	+5V DC RTN
409	+5V DC IN
410	+5V DC RTN
411	+5V DC IN
412	+5V DC RTN
413	+5V DC IN
414	+5V DC RTN
415	+5V DC IN
416	+5V DC RTN
417	+5V DC IN
418	+5V DC RTN
419	+5V DC IN
420	+5V DC RTN
421	+5V DC IN
422	+5V DC RTN
423	+5V DC IN
424	+5V DC RTN
425	+5V DC IN
426	+5V DC RTN
427	+5V DC IN
428	+5V DC RTN
429	+5V DC IN
430	+5V DC RTN
431	+5V DC IN
432	+5V DC RTN
433	+5V DC IN
434	+5V DC RTN
435	+5V DC IN
436	+5V DC RTN
437	+5V DC IN
438	+5V DC RTN
439	+5V DC IN
440	+5V DC RTN
441	+5V DC IN
442	+5V DC RTN
443	+5V DC IN
444	+5V DC RTN
445	+5V DC IN
446	+5V DC RTN
447	+5V DC IN
448	+5V DC RTN
449	+5V DC IN
450	+5V DC RTN
451	+5V DC IN
452	+5V DC RTN
453	+5V DC IN
454	+5V DC RTN
455	+5V DC IN
456	+5V DC RTN
457	+5V DC IN
458	+5V DC RTN
459	+5V DC IN
460	+5V DC RTN
461	+5V DC IN
462	+5V DC RTN
463	+5V DC IN
464	+5V DC RTN
465	+5V DC IN
466	+5V DC RTN
467	+5V DC IN
468	+5V DC RTN
469	+5V DC IN
470	+5V DC RTN
471	+5V DC IN
472	+5V DC RTN
473	+5V DC IN
474	+5V DC RTN
475	+5V DC IN
476	+5V DC RTN
477	+5V DC IN
478	+5V DC RTN
479	+5V DC IN
480	+5V DC RTN
481	+5V DC IN
482	+5V DC RTN
483	+5V DC IN
484	+5V DC RTN
485	+5V DC IN
486	+5V DC RTN
487	+5V DC IN
488	+5V DC RTN
489	+5V DC IN
490	+5V DC RTN
491	+5V DC IN
492	+5V DC RTN
493	+5V DC IN
494	+5V DC RTN
495	+5V DC IN
496	+5V DC RTN
497	+5V DC IN
498	+5V DC RTN
499	+5V DC IN
500	+5V DC RTN

* REFERENCE TABLE DEPENDS ON MOTOR TIME CONSTANT- CONSULT FACTORY

Model	TP5, 6, 12	TP3, 4, 7, 10, J1-14B	CC LIMIT	R12	R13, 70
5-420-048-01	1 A/V	1 A/V	3V	1M	0.1R,1%.5W
5-714-048-01	2 A/V	2 A/V	1.5V	1M	.05R,1%.5W
6-420-048-01	1 A/V	1 A/V	3V	1M	0.1R,1%.5W
6-714-048-01	2 A/V	2 A/V	1.5V	1M	.05R,1%.5W

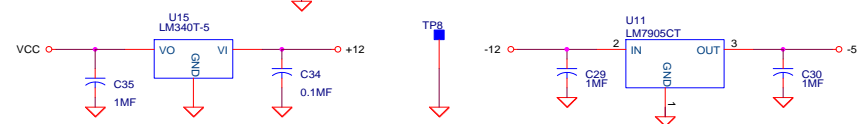

NOTES: ENB WHEN SW1 BAT IS TOWARDS BOARD CENTER

ELTROL CORPORATION
CARLSBAD, CA

Title: FUNCTIONAL DIAGRAM 52 SERIES AMPLIFIER
Size: C Document Number: 3900052 DC.FNC Rev:
Date: Wednesday, January 16, 2008 Sheet 1 of 1

EUROCARD SERIES 52 LINEAR DC SERVO AMPLIFIER

MOUNTING DIMENSIONS

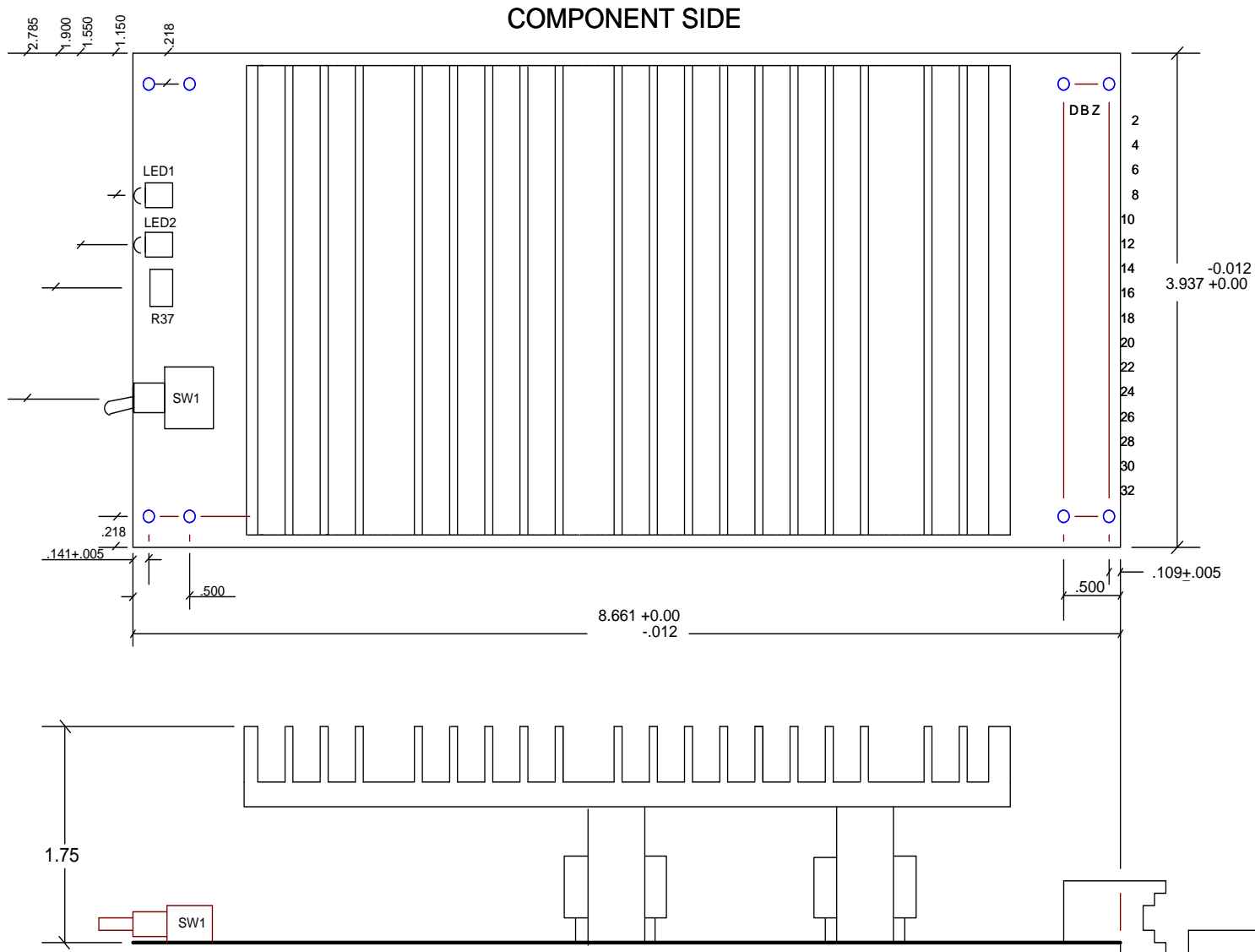

NOTES: 1. ALL DIMENSIONS SPECIFIED IN INCHES
 2. ALL TOLERANCES ARE: +.002 UNLESS OTHERWISE SPECIFIED
 3. DO NOT SCALE

ELTROL CORPORATION CARLSBAD, CA		
Title	SERIES 52 DATA SHEET OUTLINE	
Size	Document Number	Rev
B	3900052 OUTLINE.SCH	
Date: Tuesday, August 14, 2001 Sheet 1 of 1		